

# DC 3108NL SERIES FAN

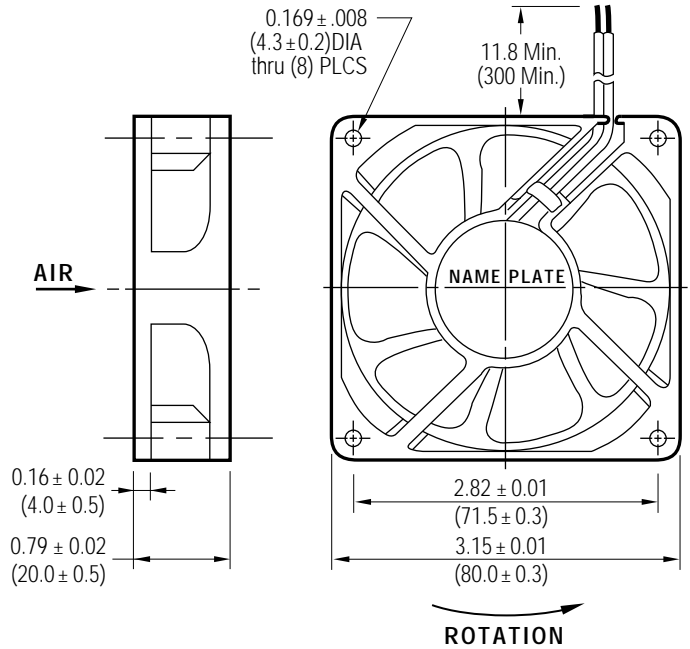

## FEATURES:

- Size 3.15 in sq. X 0.79 in (80mm sq. X 20mm)
- Airflow 27-44 CFM
- Weight 3.1 oz (88g)
- Noise 26 - 42 dBA
- Lead Wire AWG 24, Red/Black, UL1007, CSA TR-64 (Optional)

Impeller and Venturi UL94V-0 Reinforced plastic

- † Non-stock item, may be subject to lead time
- †† Rib-type is a non-stock item, may be subject to lead time

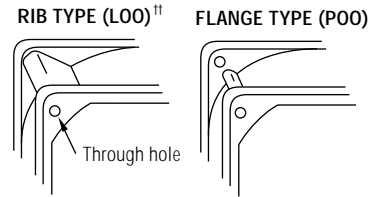
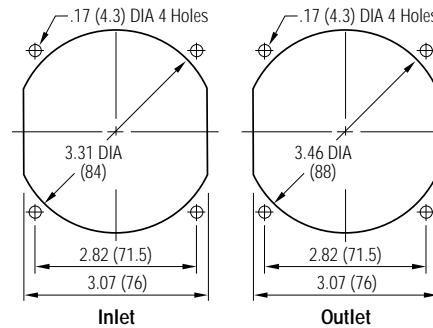

Dimensions are in inches. ( ) are in millimeters

MODEL	VOLTAGE (V)	RANGE (V)	POWER (W)	CURRENT (mA)	SPEED (RPM)	NOISE (dBA)	NOISE NPEL (BELS)				PRESSURE (in H <sub>2</sub> O)	AIRFLOW (CFM)	MODEL	VOLTAGE (V)	RANGE (V)	POWER (W)	CURRENT (mA)	SPEED (RPM)	NOISE (dBA)	NOISE NPEL (BELS)				PRESSURE (in H <sub>2</sub> O)	AIRFLOW (CFM)
							100%	80%	60%	20%										100%	80%	60%	20%		
3108NL-04W-B10-P00	12	6 - 13.8	1.08	90	2350	26	4.51	4.51	4.69	4.39	0.08	27	3108NL-05W-B10-P00	24	15 - 27.6	1.30	50	2350	26	4.51	4.51	4.69	4.39	0.08	27
B20-P00†	12	6 - 13.8	1.32	110	2600	29	4.90	4.90	5.00	4.60	0.10	30	B20-P00†	24	15 - 27.6	1.44	60	2600	29	4.90	4.90	5.00	4.60	0.10	30
B30-P00	12	6 - 13.8	1.68	140	2950	32	4.97	4.99	5.32	4.97	0.13	35	B30-P00	24	15 - 27.6	1.68	70	2950	32	4.97	4.99	5.32	4.97	0.13	35
B40-P00†	12	6 - 13.8	2.40	200	3350	38	5.48	5.57	5.75	5.25	0.18	41	B40-P00†	24	15 - 27.6	2.64	110	3350	38	5.48	5.57	5.75	5.25	0.18	41
B50-P00	12	6 - 13.8	3.36	280	3750	42	5.65	5.52	5.72	5.54	0.20	44	B50-P00	24	15 - 27.6	3.60	150	3750	42	5.65	5.52	5.72	5.54	0.20	44

